

PARTS LIST

Remote Engine Starter Unit Kit P/N 08E91-E54-100

Transmitter

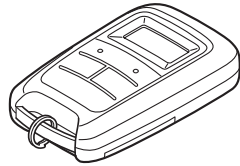

Control unit

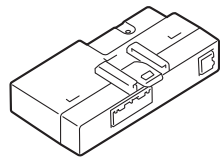

Antenna

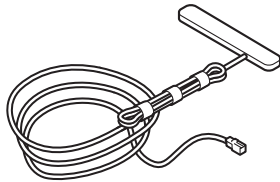

ID label



Remote Control Engine Starter Attachment Kit P/N 08E92-TP6-100A

Engine starter harness

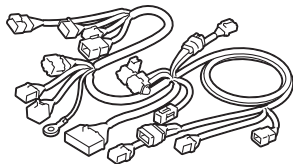

Control unit bracket

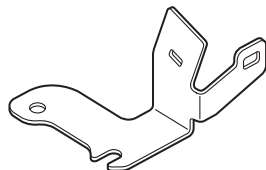

3 Relays

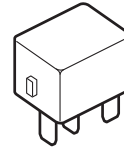

Ground bolt



21 Wire ties

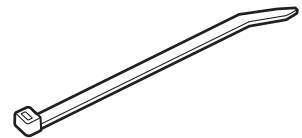

2 Long wire ties

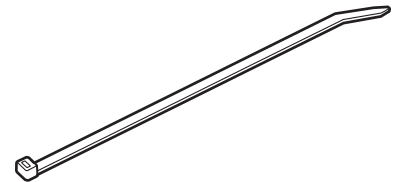

7 Urethane tapes

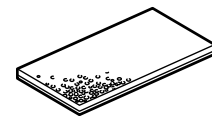

Clip



Caution label



Fuse label

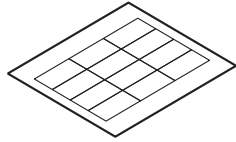

Accessory User's Information Manual

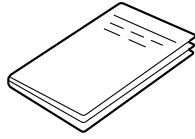

Quick Start Guide

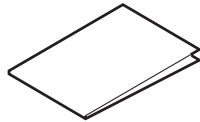

TOOLS AND SUPPLIES REQUIRED

Flat-tip screwdriver
Phillips screwdriver
Small rubber mallet
Ratchet
10 mm Socket
10 mm Open end wrench
Torque wrench
Isopropyl alcohol
Shop towel
Tape measure
Scissors
HDS/MVCI
Masking tape
Diagonal cutters
Ruler
Tape
Felt-tip pen

The following tools are available through the Honda Tool and Equipment Program. On the iN, click on: Service > Service Bay > Tool and Equipment Program, then enter the number under "Search". Or, call 888-424-6857.

- Trim Tool Set (T/N SOJATP2014)
- Plastic Trim Tool (T/N SILTRIMTL10)

Illustration of the Remote Control Engine Starter in the Vehicle

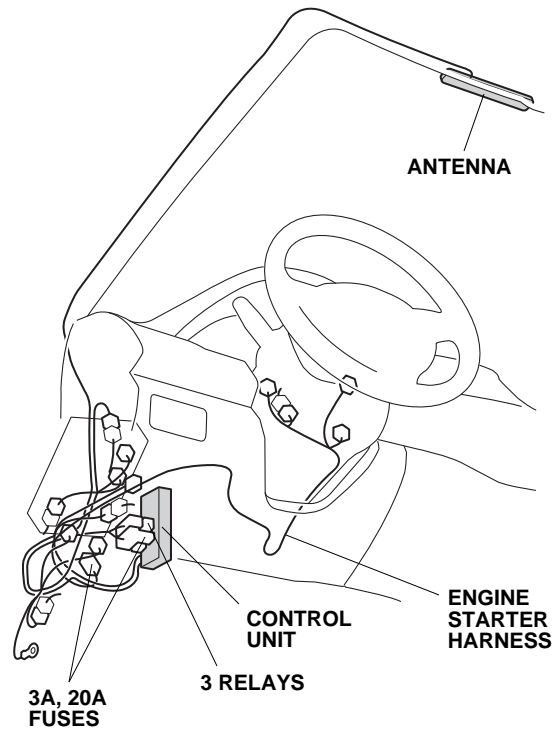

QB71803AK

INSTALLATION

Customer Information: The information in this installation instruction is intended for use only by skilled technicians who have the proper tools, equipment, and training to correctly and safely add equipment to your vehicle. These procedures should not be attempted by "do-it-yourselfers."

1. Make sure you have the anti-theft codes for the audio and navigation system (if equipped), then write down the radio station presets.
2. Disconnect the negative cable from the battery.

3. Attach the ID label.
 - Using isopropyl alcohol on a shop towel, clean the area where the ID label will attach.
 - Attach the ID label to the transmitter in the area as shown.

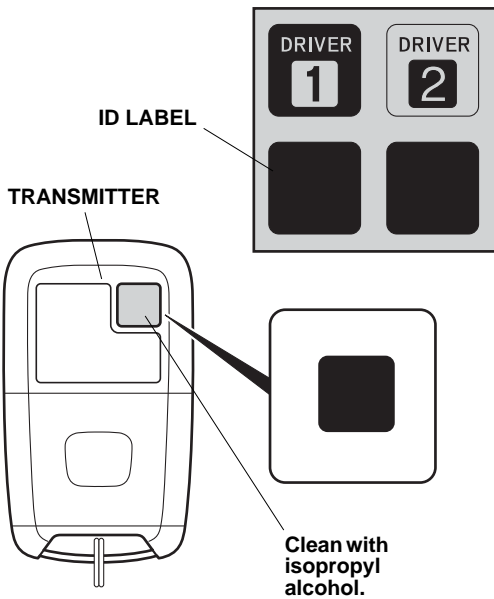

QB32111CH

4. Remove the driver's sunvisor holder.

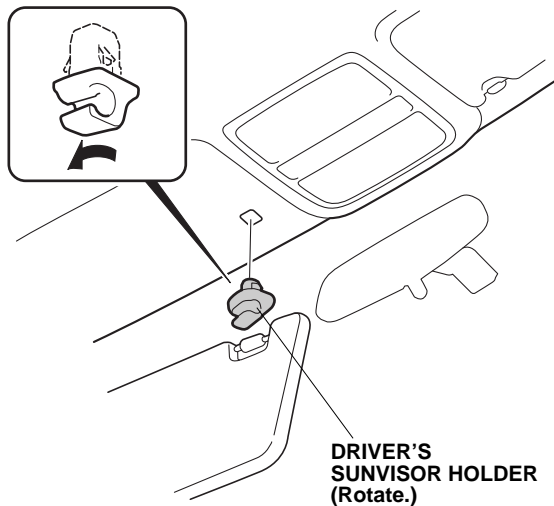

QB31602AH

5. Wrap the end of a flat-tip screwdriver with tape. Locate the slot in the bracket cover, and insert the flat-tip screwdriver into the slot. Push the hook with the screwdriver.

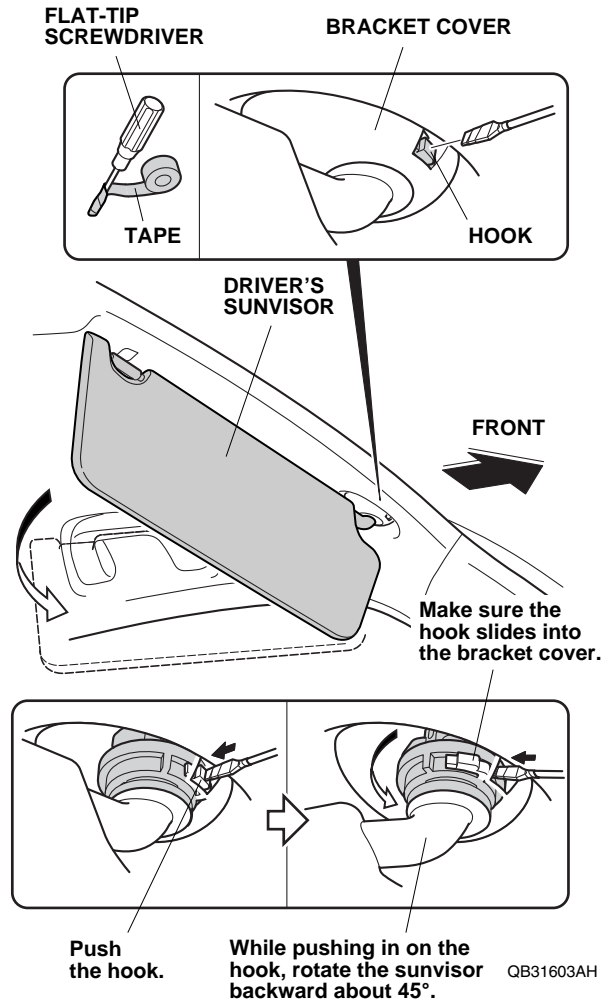

6. While pushing in on the hook, rotate the driver's sunvisor backward about 45°. Make sure the hook slides into the bracket cover.

NOTE: If the hook did not stay pushed in, return the driver's sunvisor to its original position and repeat steps 5 and 6.

- Remove the driver's sunvisor (unplug the vehicle connector).

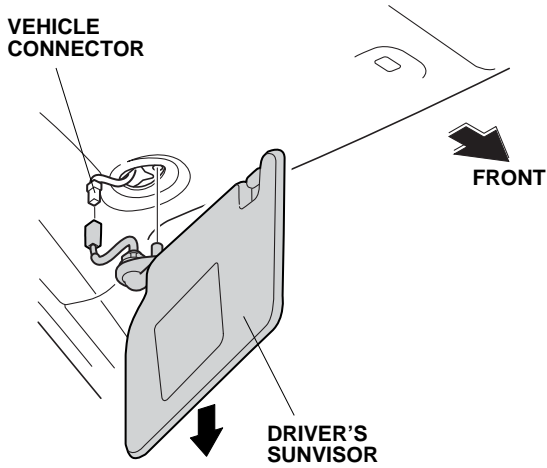

QB31604AH

- Pull away the door opening seal from the driver's A-pillar trim.

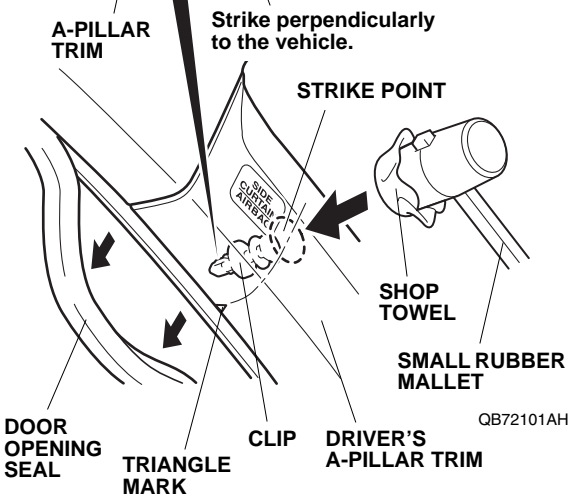
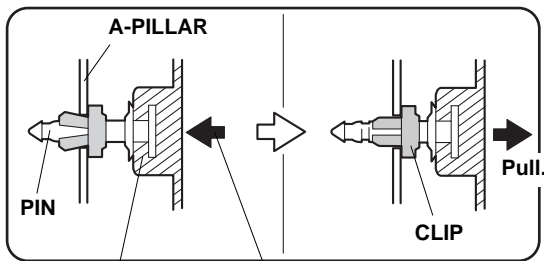

QB72101AH

- Using a small rubber mallet and a shop towel, gently tap the driver's A-pillar trim at the position shown to release the clip.

- Pull away the door opening seal from the driver's A-pillar trim. Remove the driver's A-pillar trim (two clips).

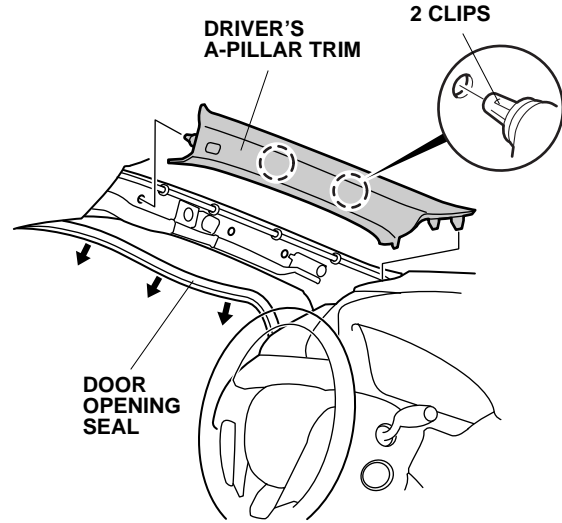

6D18070Y

- Remove and discard the clip from the driver's A-pillar trim, and install a new clip (supplied) on the driver's A-pillar trim.

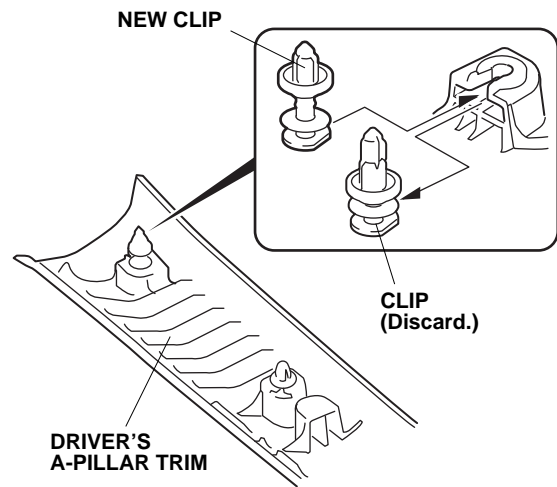

6D18080Y

12. Remove the driver's dashboard lower cover (eight clips, two hooks, and vehicle connectors).

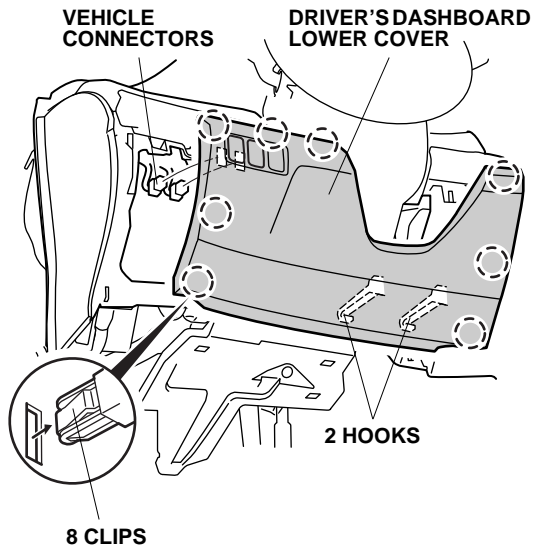

QB71601AK

13. Remove the driver's dashboard under cover (three clips and one pin).

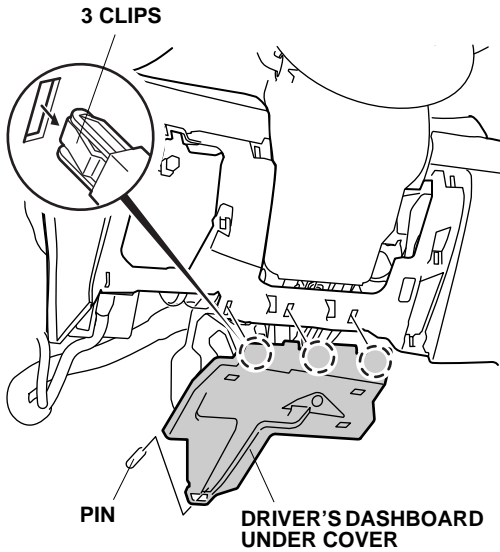

6D18040Y

14. Remove the driver's front door sill trim (four clips, two retaining tabs, and two hooks).

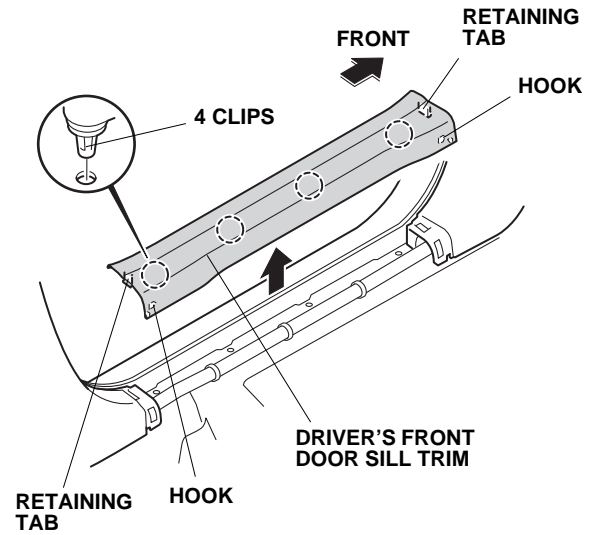

QB61252AK

15. Pull away the door opening seal, and remove the driver's kick panel (two clips).

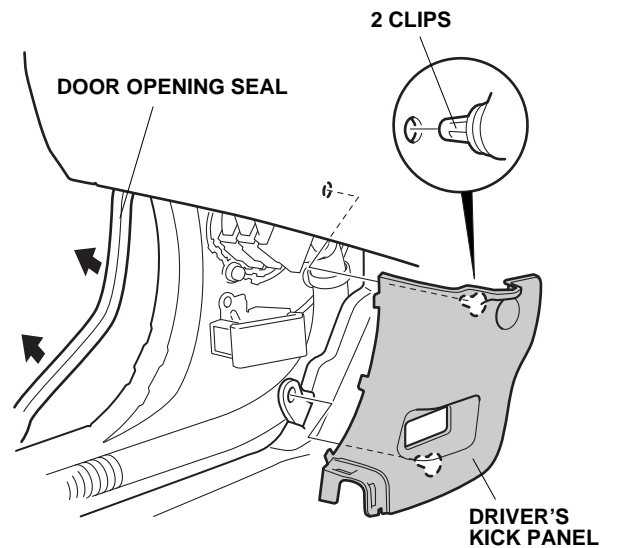

932503AS

16. Pull away the door opening seal, remove the driver's dashboard side lid (three clips, four pawls, and three hooks).

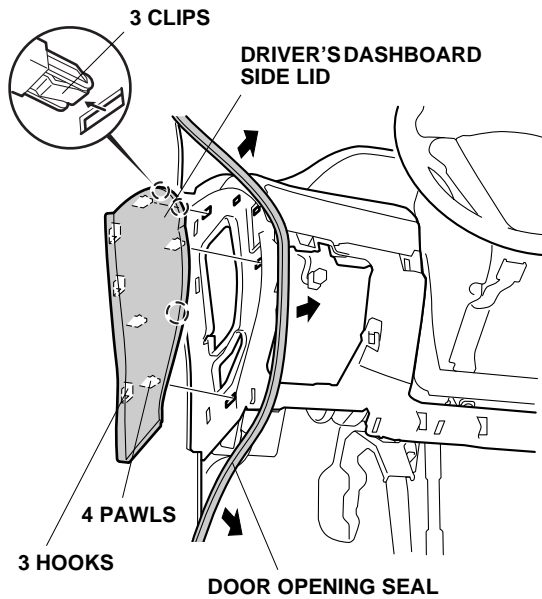

6D1805BY

17. Lower the tilt lever, and release the column band (two clips). Reconnect the negative cable to the battery, then press the engine start/stop button to select the ON mode.

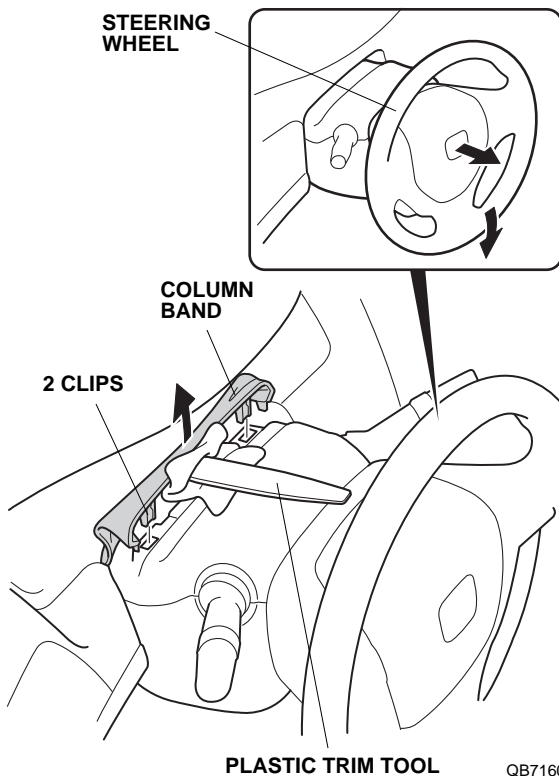

QB71603AK

18. Turn the steering wheel 90° counterclockwise. Using a plastic trim tool, release the retaining tab.

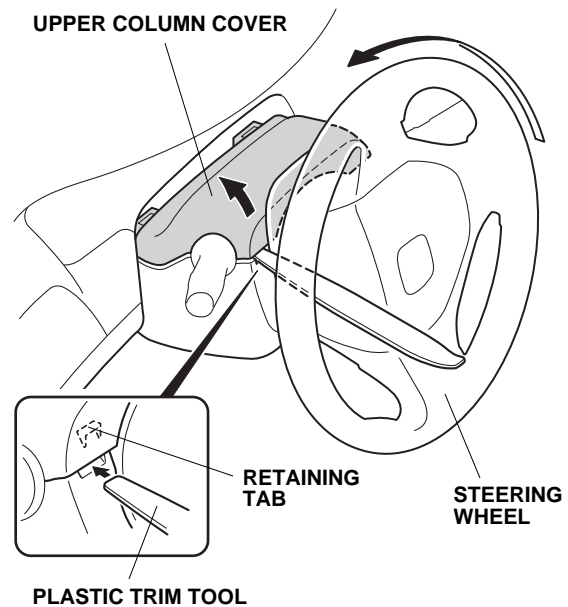

QB71604AK

19. Turn the steering wheel 180° clockwise. Using a plastic trim tool, release the retaining tab.

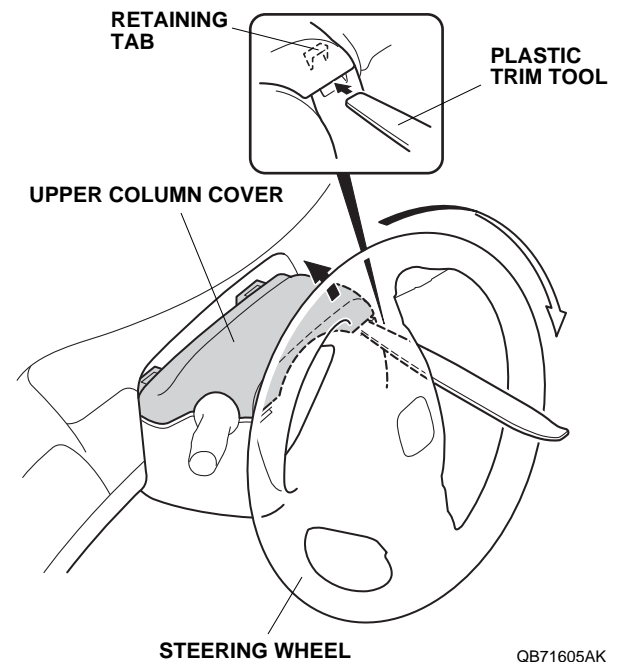

QB71605AK

20. Remove the upper column cover (two retaining tabs and two hooks).

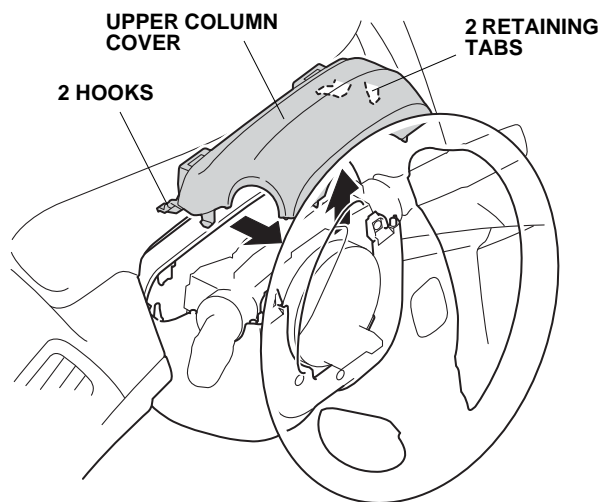

QB71606AK

21. Remove one self-tapping screw from the lower column cover.

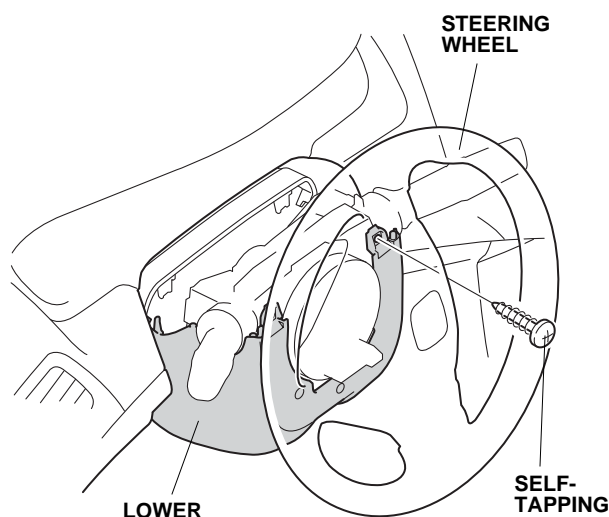

QB71610AK

22. Turn the steering wheel 180° counterclockwise, and remove the other self-tapping screw from the lower column cover.

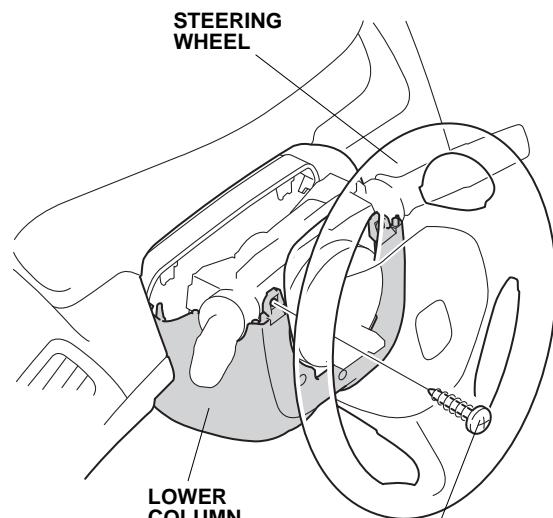

SELF-TAPPING SCREW QB71609AK

23. Remove the lower column cover (one self-tapping screw).

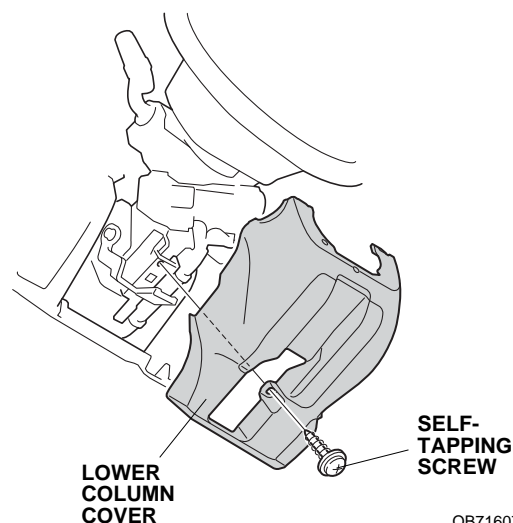

QB71607AK

24. Press the engine start/stop button to select the OFF mode. Disconnect the negative cable from the battery.

25. Remove the vehicle unit (two bolts, vehicle connectors, and vehicle relay block).

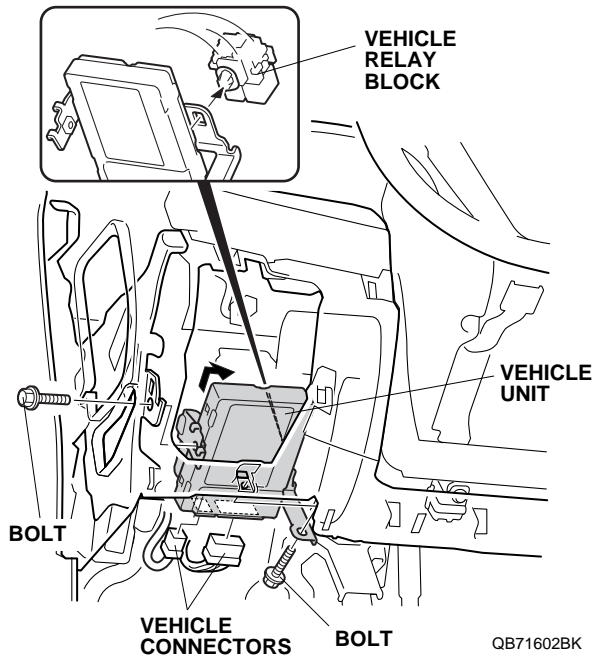

26. Remove the vehicle unit from the vehicle bracket (vehicle connectors).

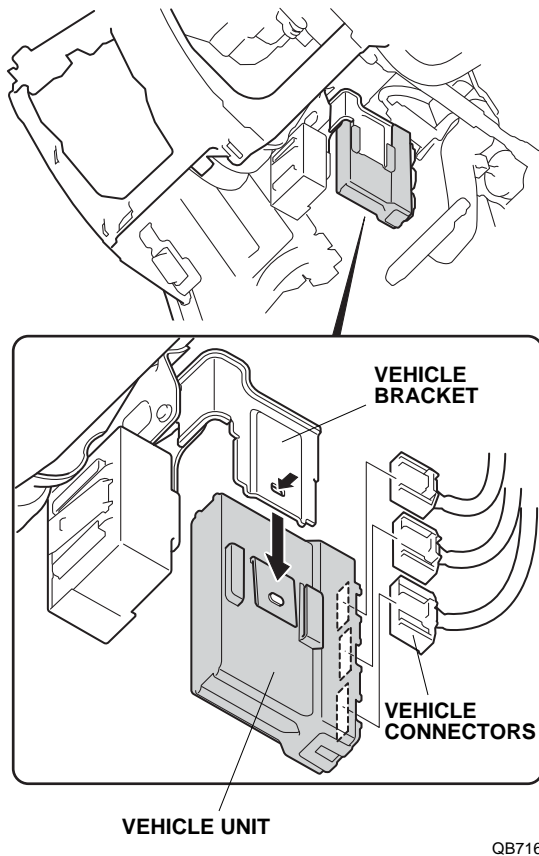

Installing the Antenna

27. Using scissors, cut one urethane tape in half. Wrap two halves of urethane tape to the antenna cable as shown.

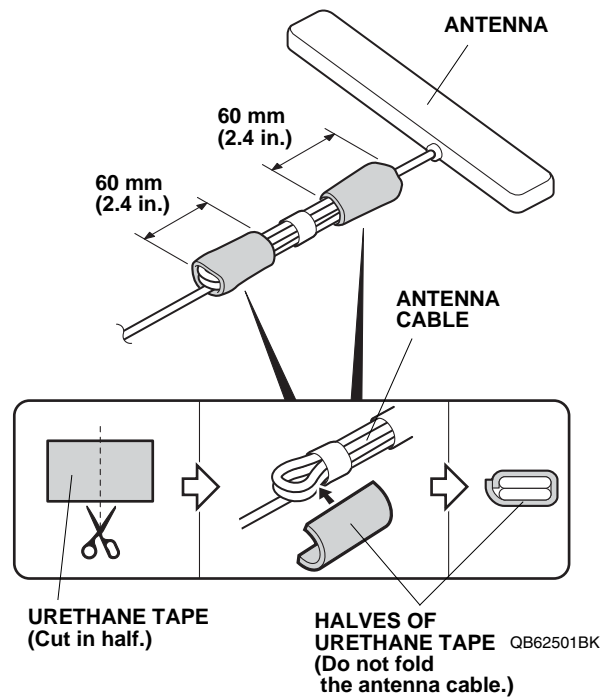

28. Starting near the antenna end of the cable, wrap two urethane tapes around the antenna cable at the measurements shown.

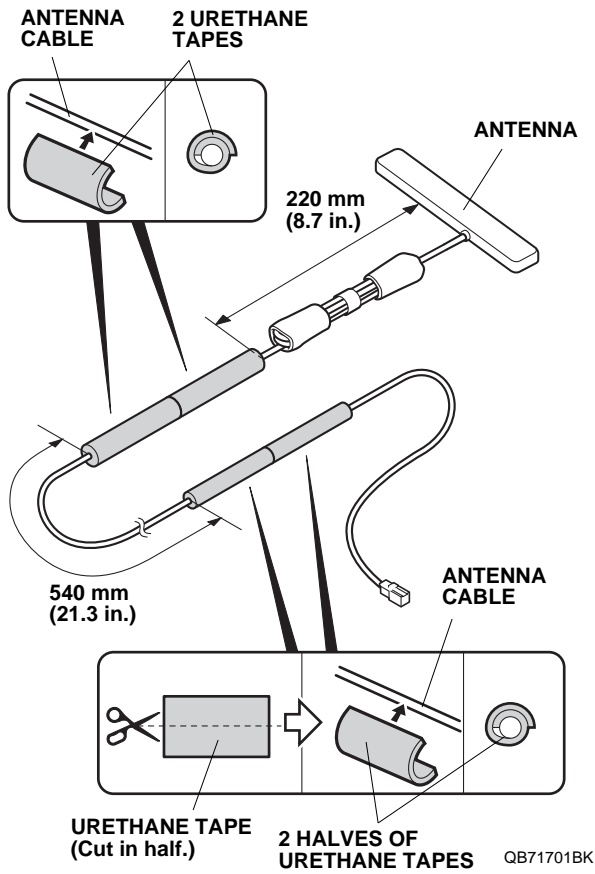

29. Using scissors, cut one urethane tape in half. Wrap the two halves of urethane tape around the antenna cable at the measurements shown.

30. Attach the antenna.
- Attach masking tape to the windshield at the measurement shown.

With Camera Cover

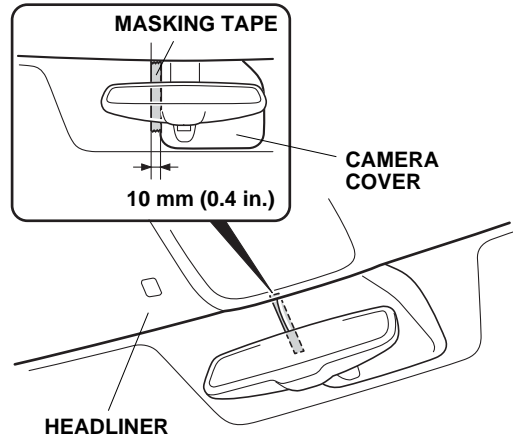

QB51403BH

Without Camera Cover

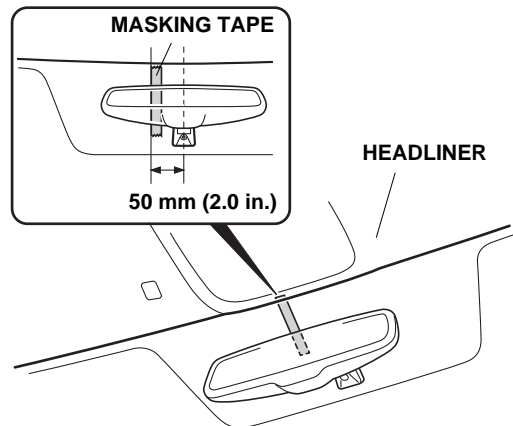

QB51402BH

- Fold the adhesive backing of the antenna as shown.

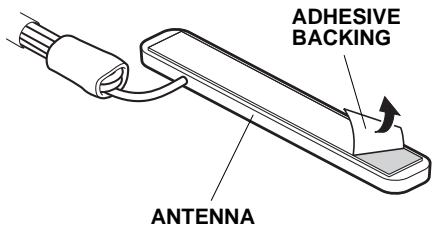

QB51401CH

- Using isopropyl alcohol on a shop towel, thoroughly clean the windshield where the antenna will attach.
- Attach the antenna with masking tape. Adjust position of the antenna so there is equal spacing on both sides.

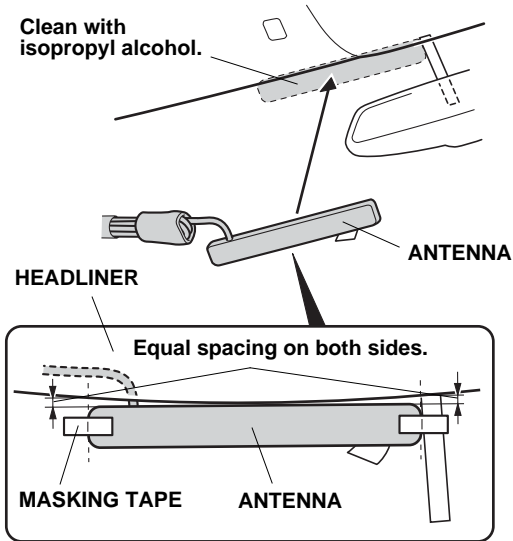

QB51404CH

- Carefully remove the adhesive backing from the antenna, and attach the antenna to the windshield. Press and hold the antenna firmly in place for 30 seconds.
- Remove the masking tape.

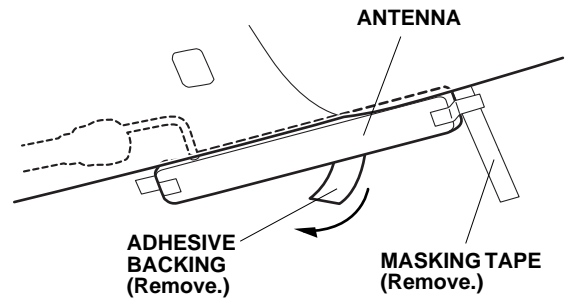

QB51405CH

31. Gently pull down the headliner, and tuck the antenna cable under the headliner. Be careful not to crease the headliner.

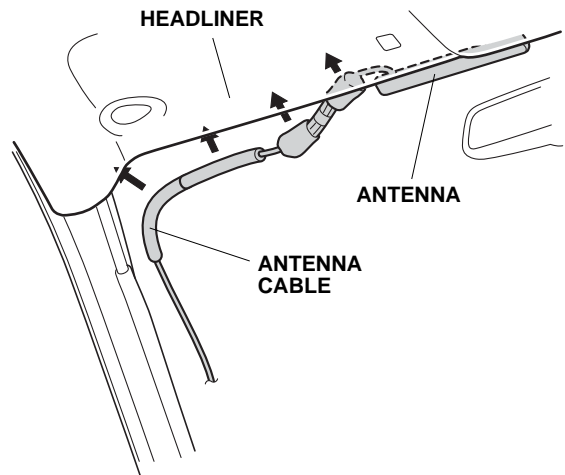

QB71702AK

32. Route the antenna cable down the A-pillar as shown. Using four wire ties, secure the antenna cable to the vehicle harness.

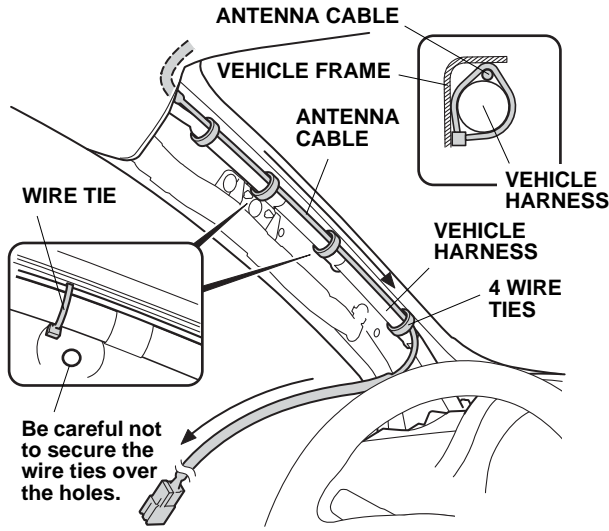

QB71703AK

33. Pull away the door opening seal. Route the antenna cable down and under the dashboard through the driver's A-pillar trim opening.

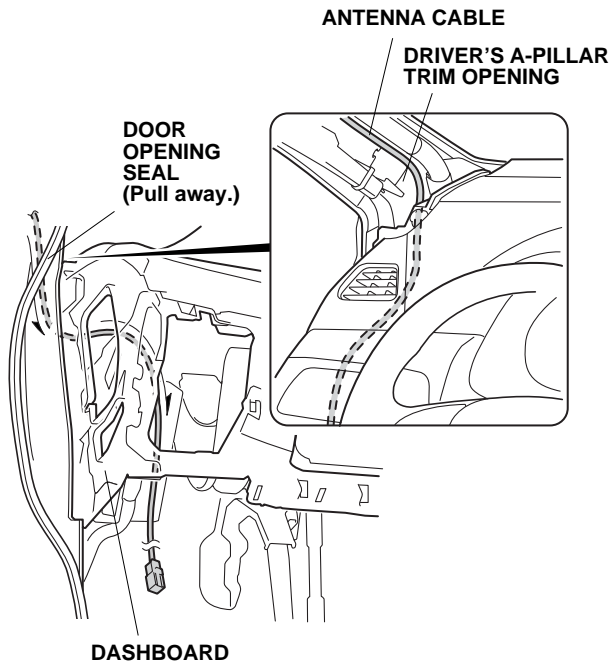

QB71704AK

Routing the Engine Starter Harness

34. Using isopropyl alcohol on a shop towel, clean the areas where the fuse labels will attach.

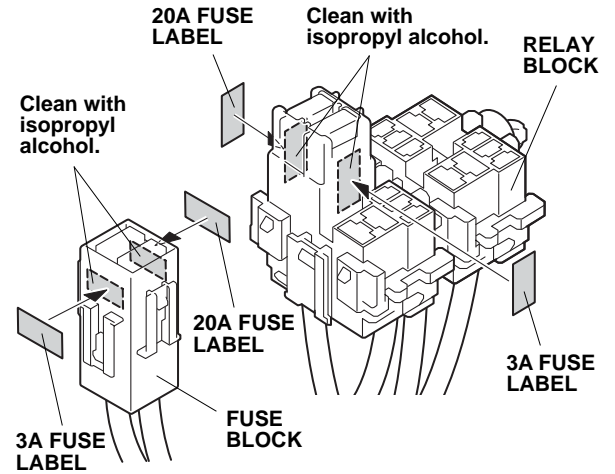

QB71705BK

35. Attach the 20A fuse labels and 3A fuse labels to the engine starter harness relay block and fuse block.
36. Install the three relays to the engine starter harness relay block.

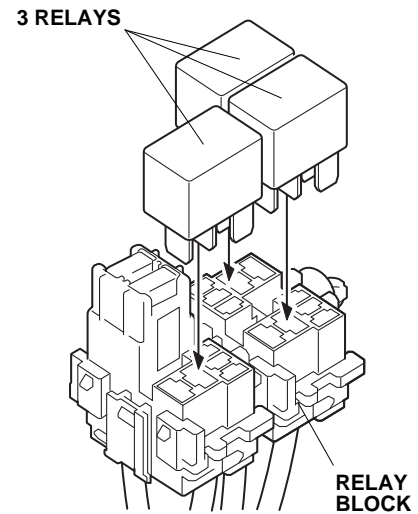

QB71706AK

37. Route the 12-pin/10-pin connector ends of the engine starter harness over the vehicle bracket towards the center of the vehicle.

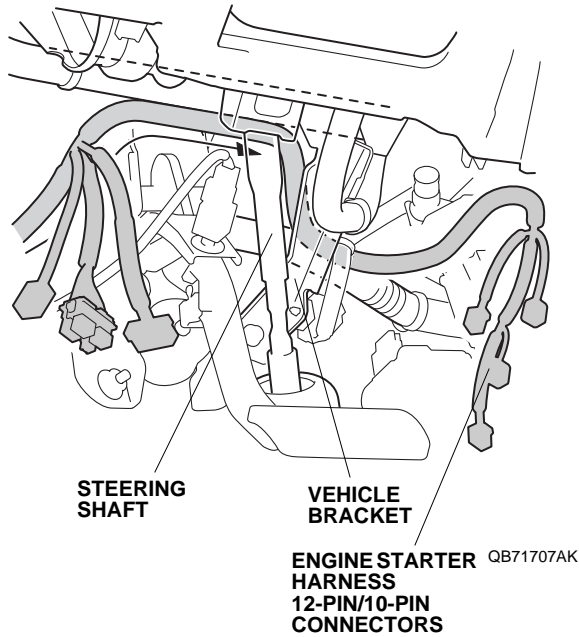

38. Align the white tape on the engine starter harness with the clip on the vehicle harness, and secure the engine starter harness to the vehicle harness using one wire tie.

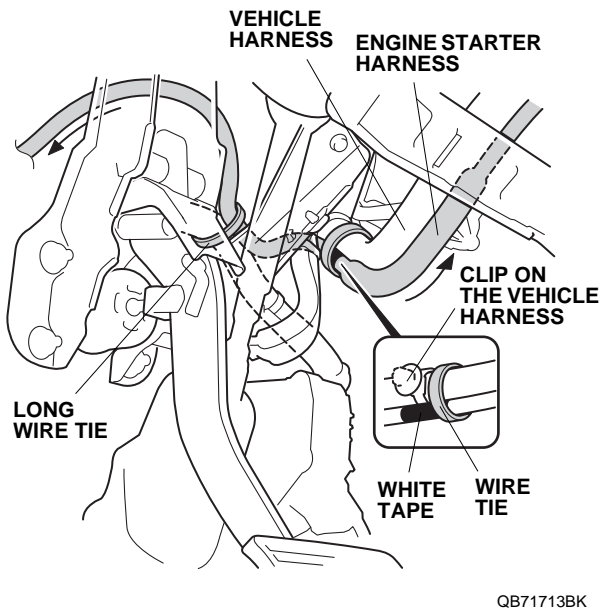

39. Using one long wire tie, secure the engine starter harness to the vehicle harness.

40. Align the white tape on the engine starter harness with the clip on the vehicle harness, and secure the engine starter harness to the vehicle harness using one wire tie.

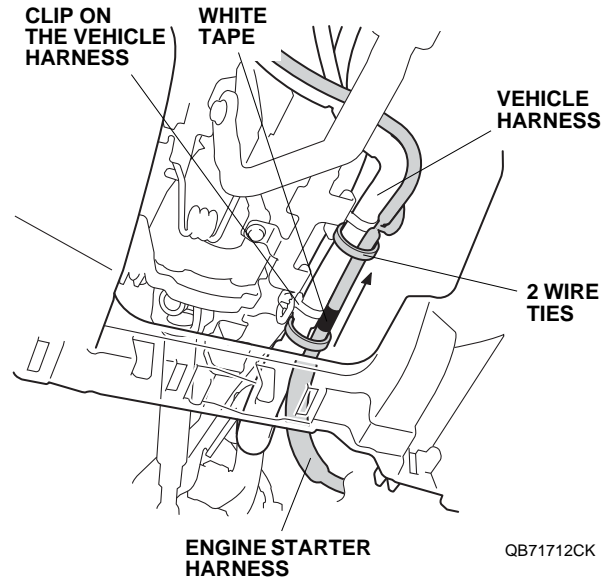

41. Using one wire tie, secure the engine starter harness to the vehicle harness.

42. Unplug the vehicle 12-pin connector, and plug it into the engine starter harness 12-pin connector. Plug the remaining engine starter harness 12-pin connector into the combination light switch.

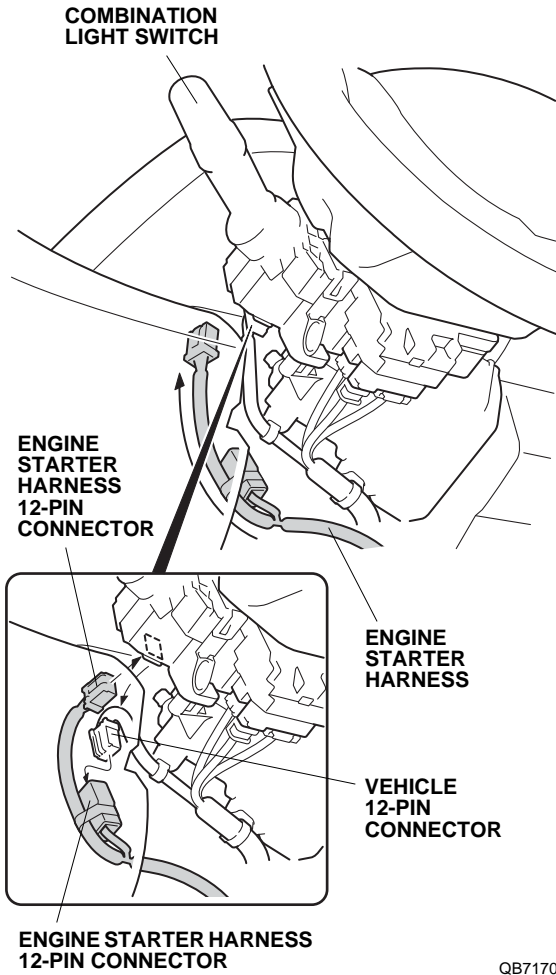

43. Unplug the vehicle 10-pin connector, and plug it into the engine starter harness 10-pin connector. Plug the remaining engine starter harness 10-pin connector into the wiper switch.

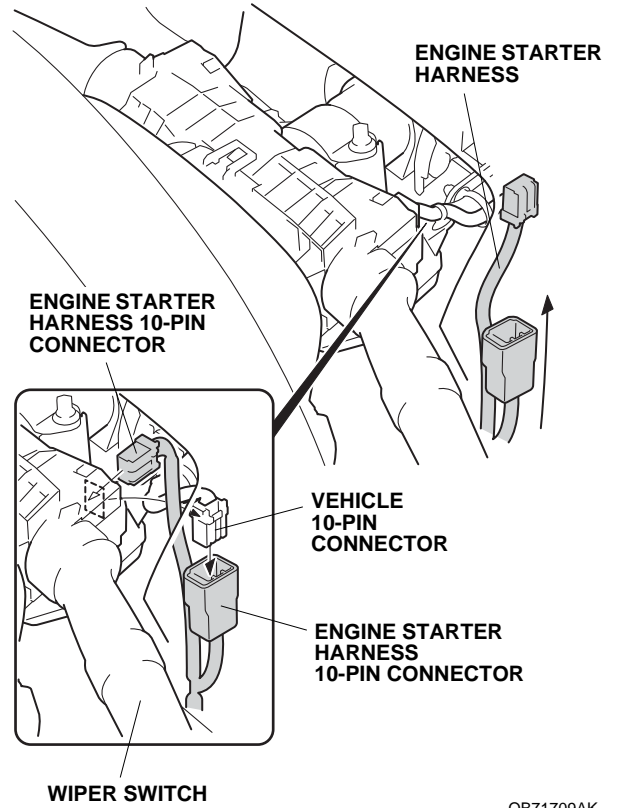

44. Align the branch point of the engine starter harness with the clip on the vehicle harness, and secure the engine starter harness to the vehicle harness using two wire ties.

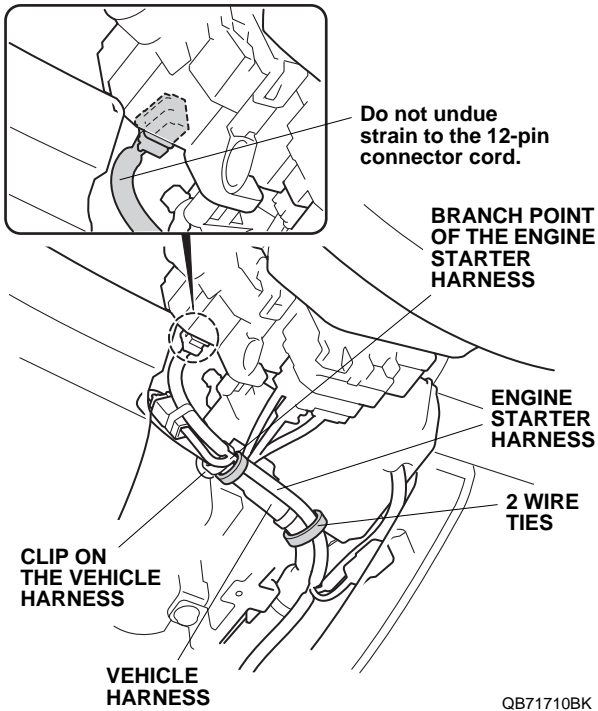

45. Align the white tape on the engine starter harness with the clip on the vehicle harness, and secure the engine starter harness to the vehicle harness using one wire tie.

NOTE: Make sure that the connectors and harness are not pinched, or are not interfering with the steering wheel when it is moved for adjustment.

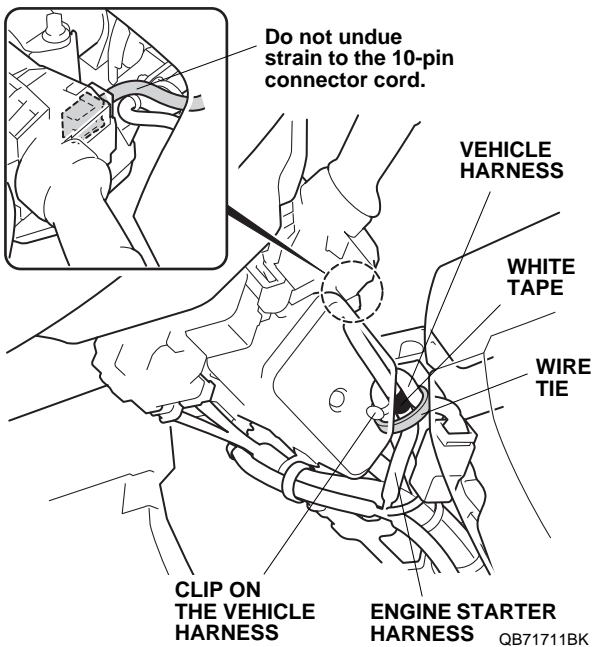

46. Using one long wire tie, secure the engine starter harness to the vehicle harness.

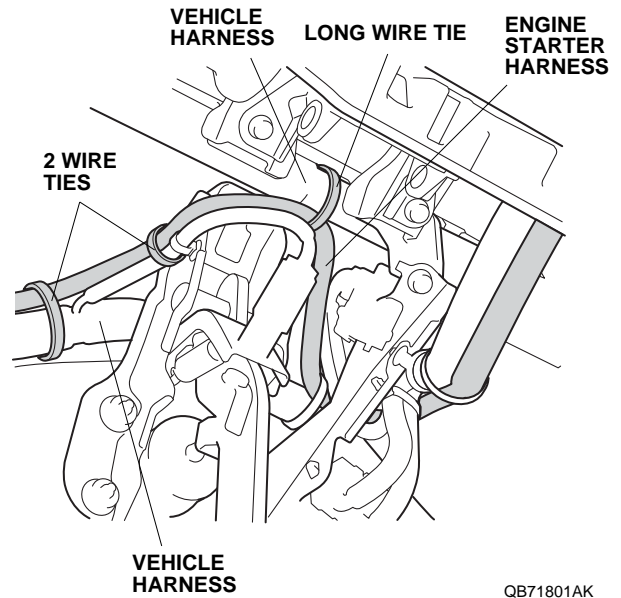

47. Using two wire ties, secure the engine starter harness to the vehicle harness.
48. Using scissors, cut one urethane tape to the measurements shown. Wrap the cut urethane tape around the engine starter harness 5-pin connector.

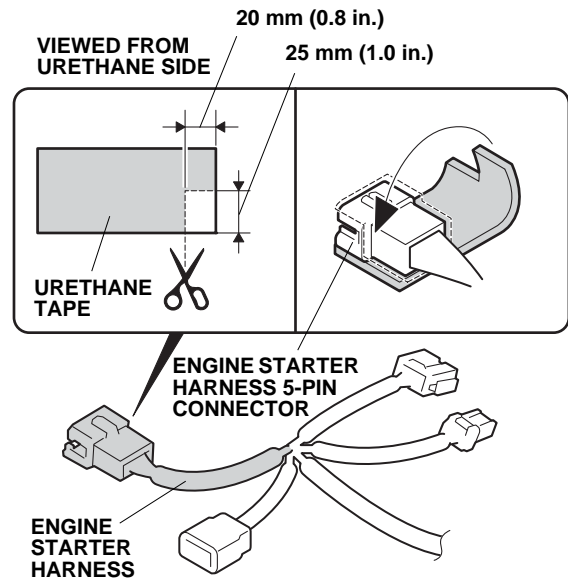

49. Unplug the vehicle 5-pin connector from the fuse box. Plug the engine starter harness 5-pin connector into the fuse box 5-pin connector. Plug the vehicle 5-pin connector into the engine starter harness 5-pin connector.

NOTICE: Make sure the engine starter harness 5-pin connector is securely connected to the fuse box 5-pin connector. A loose connection can cause the engine to stall during driving.

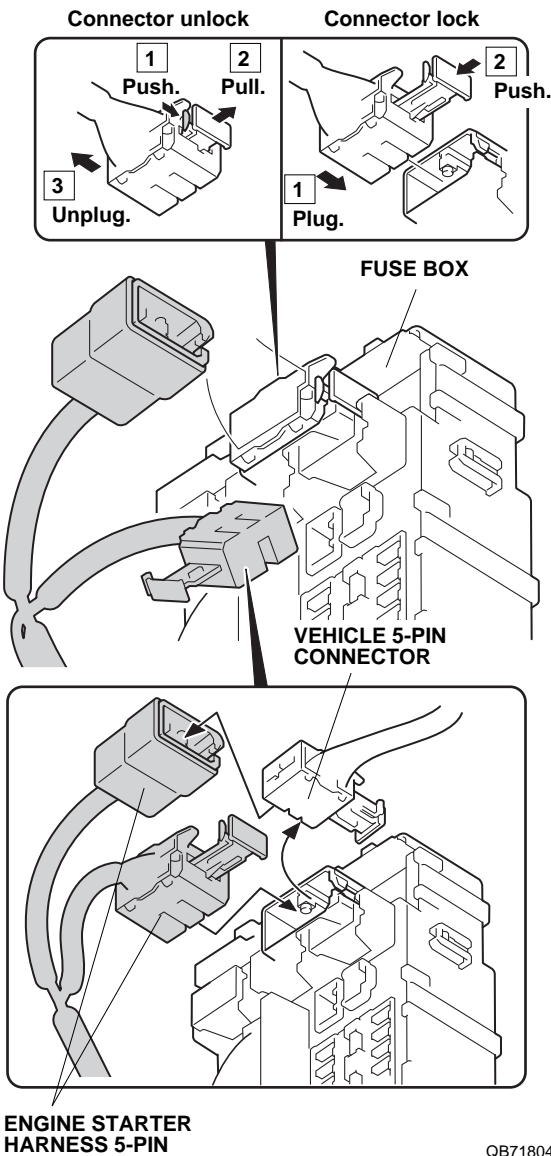

50. Using one wire tie, secure the engine starter harness and antenna cable to the vehicle harness.

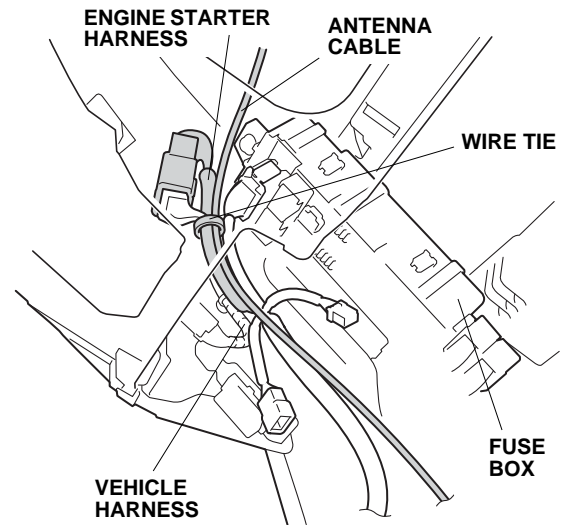

51. Plug the engine starter harness 12-pin connector into the fuse box.

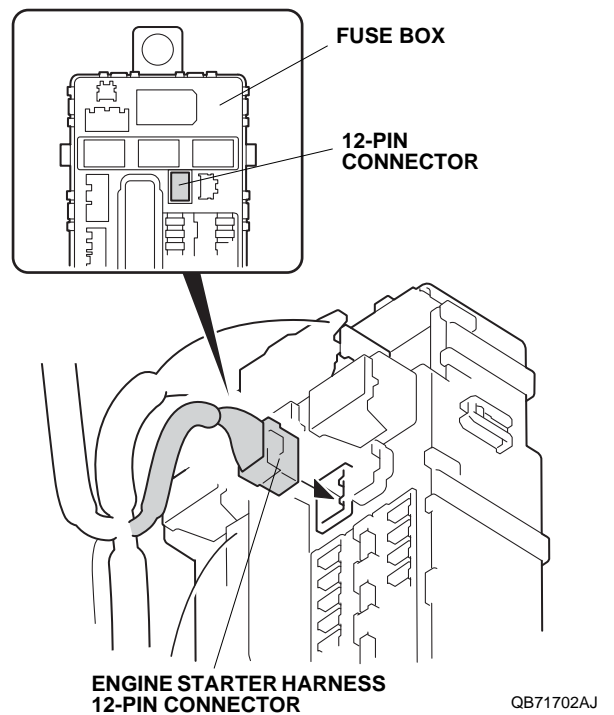

52. Unplug the vehicle 13-pin connector from the fuse box. Plug the engine starter harness 13-pin connector into the fuse box 13-pin connector. Plug the vehicle 13-pin connector into the engine starter harness 13-pin connector.

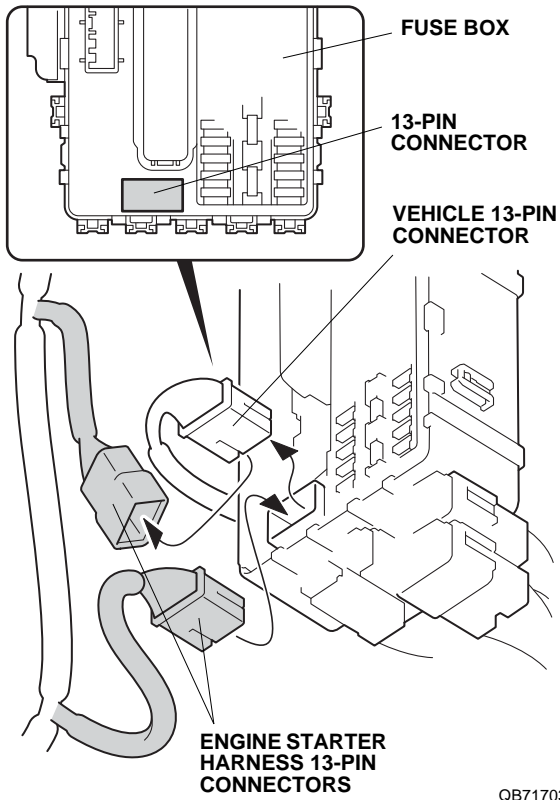

53. Using one wire tie, secure the engine starter harness 13-pin connector to the vehicle harness.

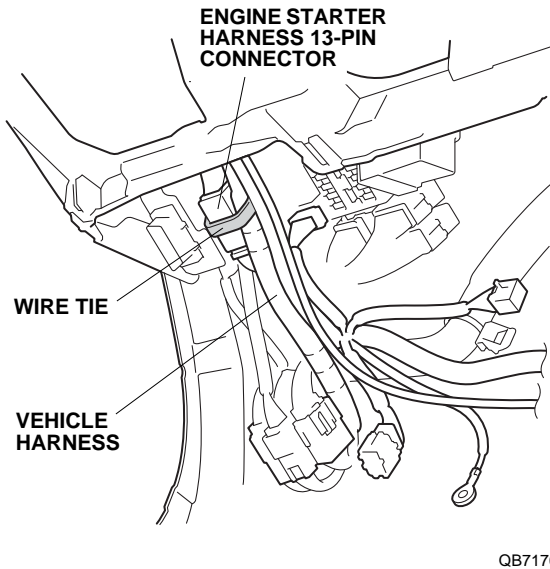

54. Attach the engine starter harness 25-pin connector to the vehicle connector as shown.

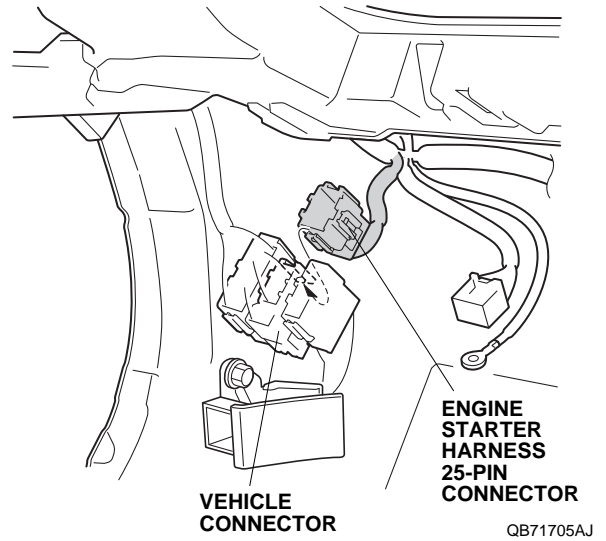

55. Unplug the vehicle 25-pin connector from the fuse box. Plug the engine starter harness 25-pin connector into the fuse box 25-pin connector. Plug the vehicle 25-pin connector into the engine starter harness 25-pin connector.

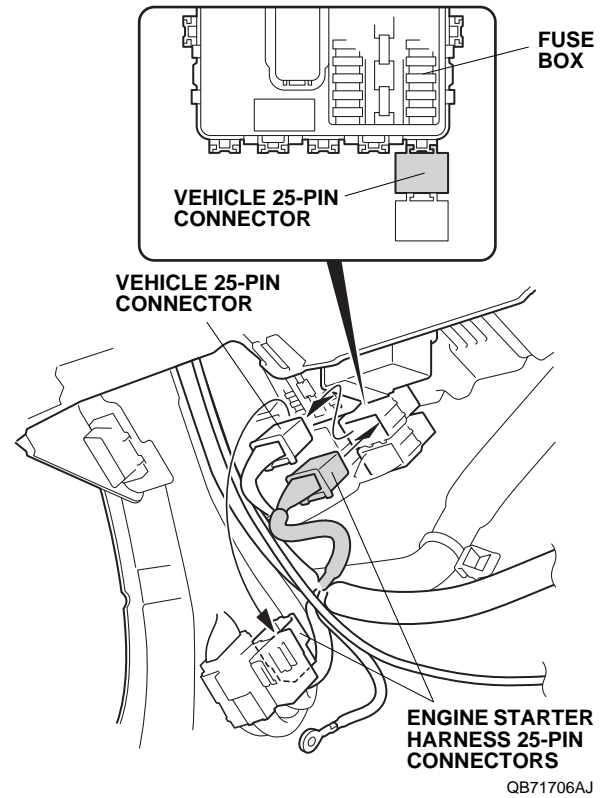

56. Remove the vehicle bolt, and install the engine starter harness ground terminal using the ground bolt.

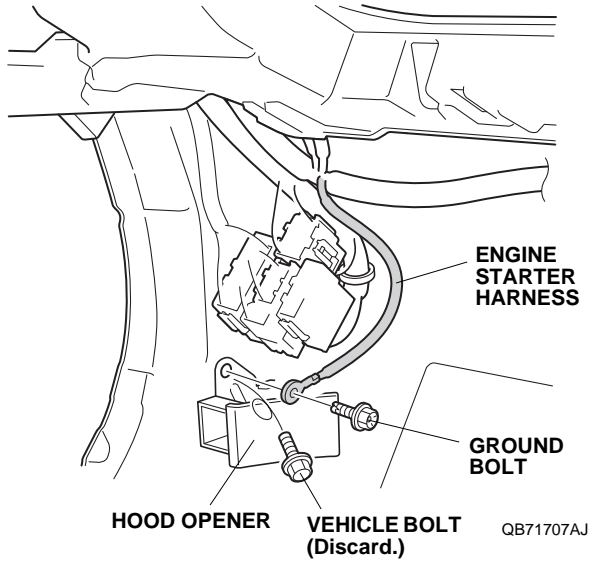

57. Using one wire tie, secure the engine starter harness to the vehicle harness.

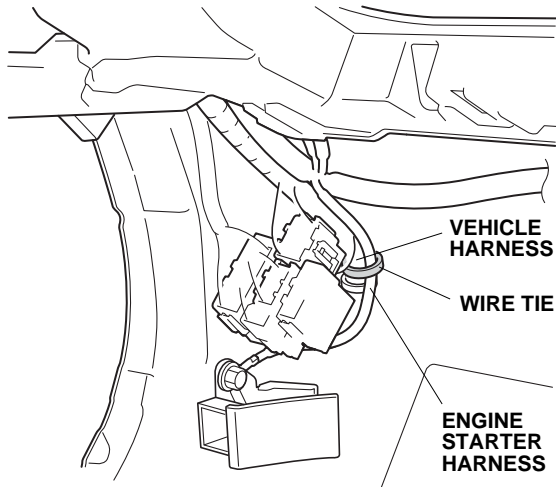

58. Using one wire tie, secure the engine starter harness and antenna cable to the vehicle harness.

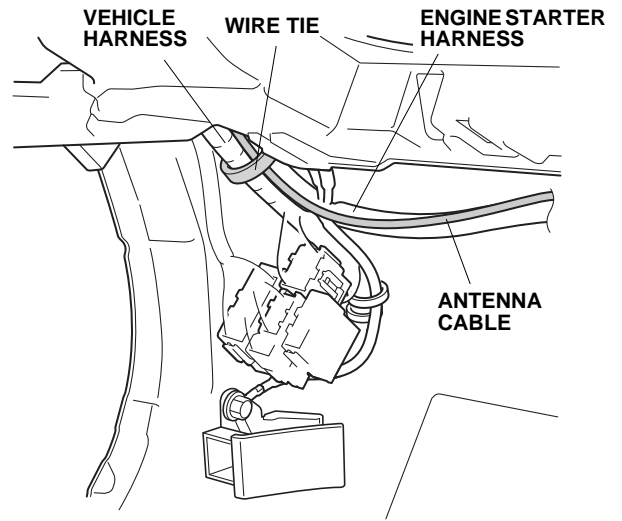

59. Remove the vehicle unit from the vehicle bracket.

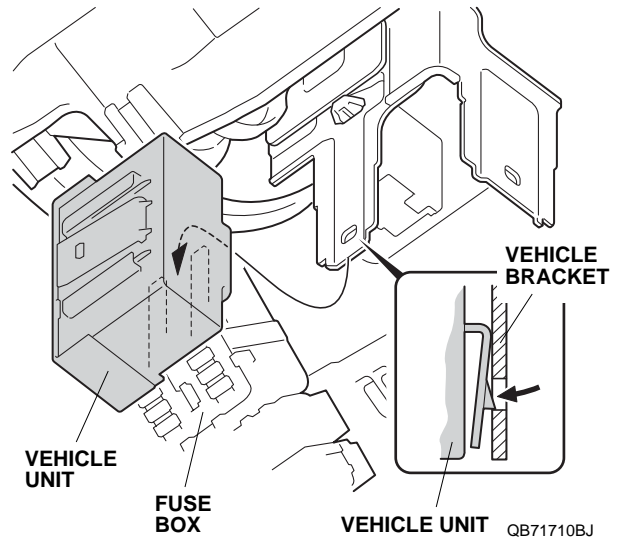

60. Unplug the vehicle 2-pin connector from the vehicle unit, and plug it into the engine starter harness 2-pin connector. Plug the remaining engine starter harness 2-pin connector into the vehicle unit.

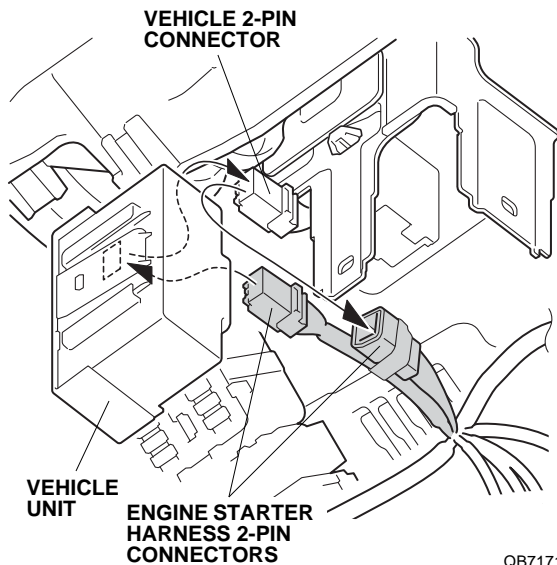

61. Reinstall the vehicle unit.
62. Plug the antenna cable connector and engine starter harness 28-pin connector into the control unit.

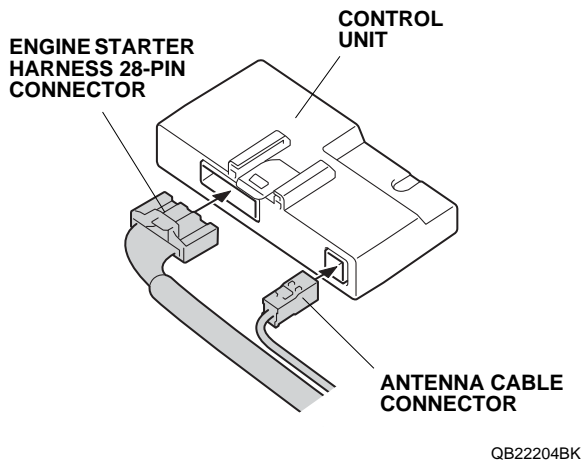

63. Install the control unit bracket to the control unit.

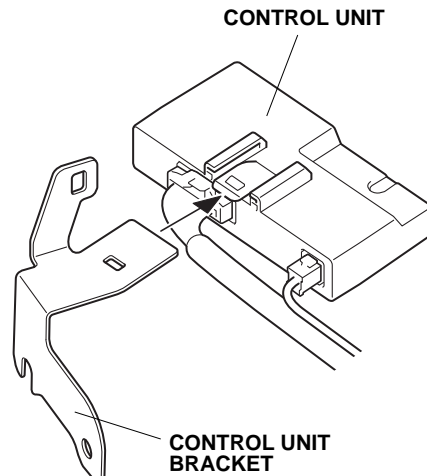

64. Remove the vehicle nut and loosen the vehicle nut.

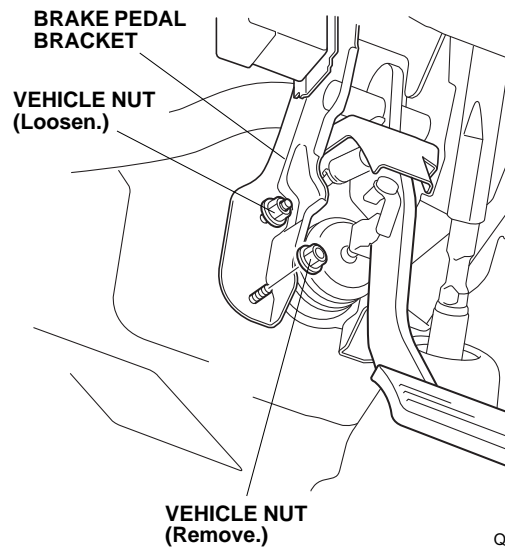

65. Secure the control unit bracket to the brake pedal bracket with two vehicle nuts.

- Vehicle nuts
Torque: 9.8 - 15.7 N·m (1.0 - 1.6 kgf·m,
7.2 - 11.6 lbf·ft)

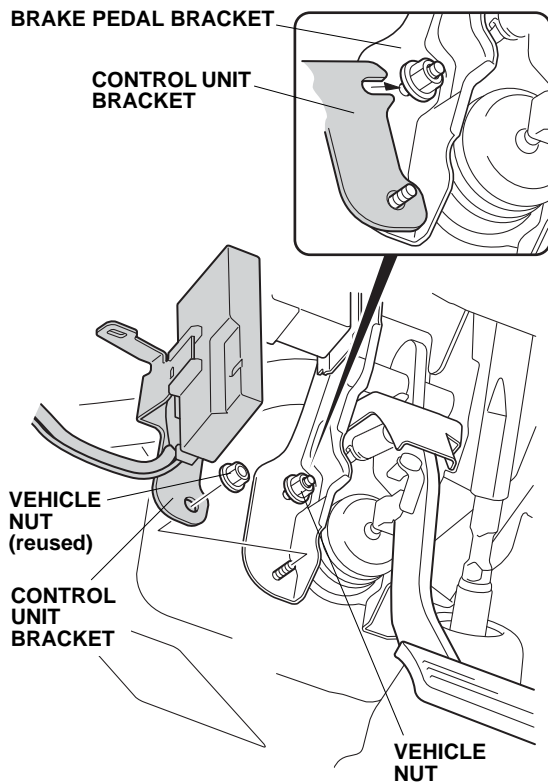

QB71714AJ

66. Using a felt-tip pen, mark the control unit bracket and vehicle nuts.

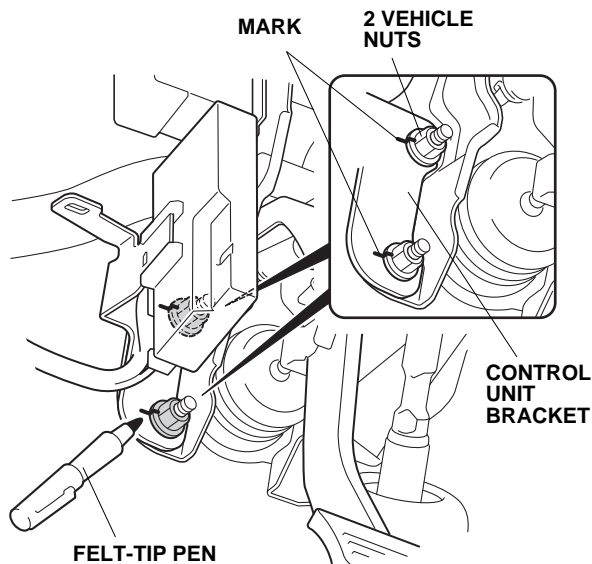

QB91101AJ

67. Attach the engine starter harness relay block to the control unit bracket.

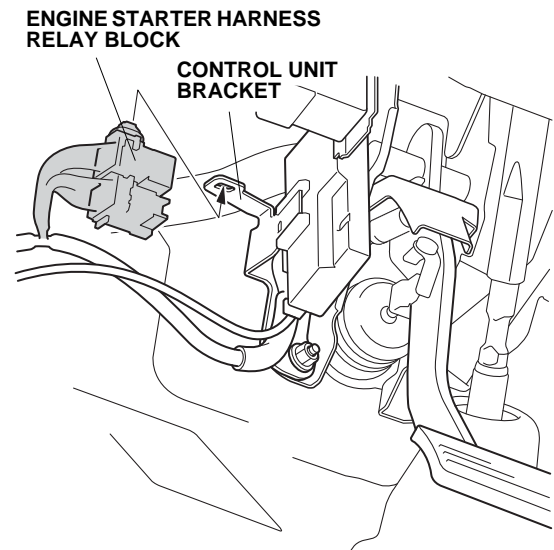

QB71715AJ

68. Reinstall the vehicle unit (removed in step 26).

69. Attach the engine starter harness fuse block to the fuse box as shown.

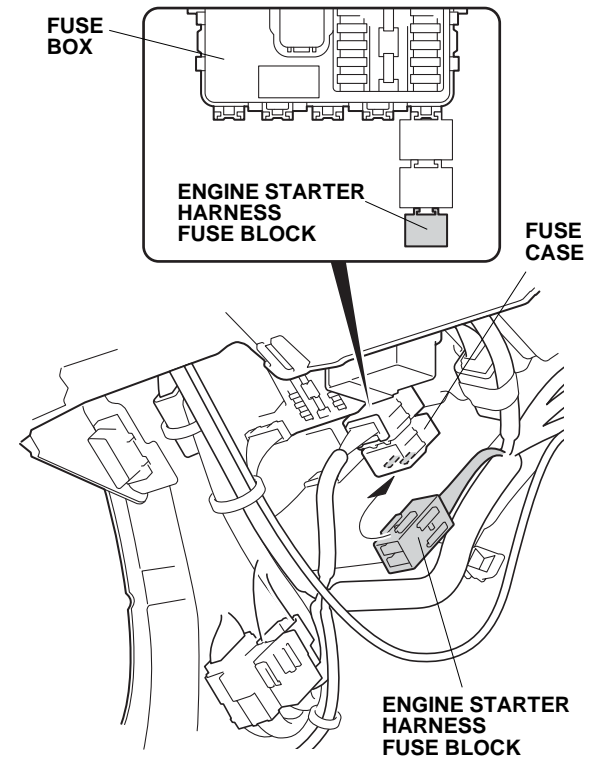

QB71719CJ

70. Using one wire tie, secure the engine starter harness to the vehicle harness.

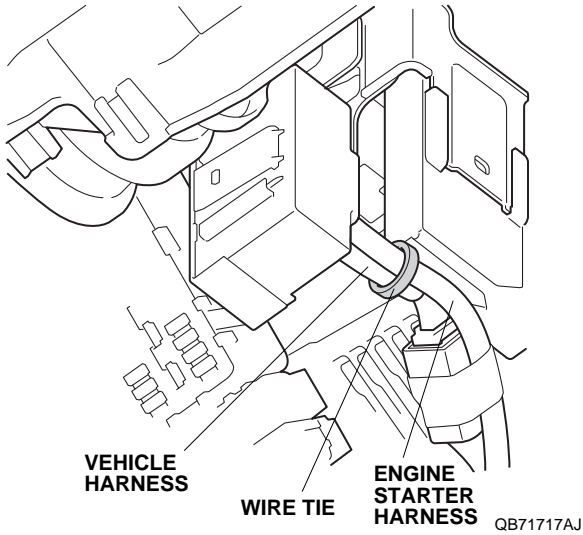

71. Align the white tape on the engine starter harness with the clip on the vehicle harness, and secure the engine starter harness and antenna cable to the vehicle harness using one wire tie.

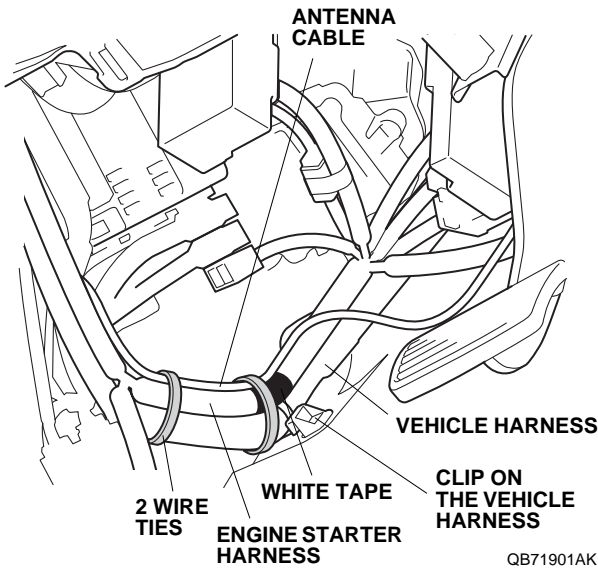

72. Using one wire tie, secure the engine starter harness and antenna cable to the vehicle harness.

73. Using one wire tie, secure the antenna cable to the engine starter harness.

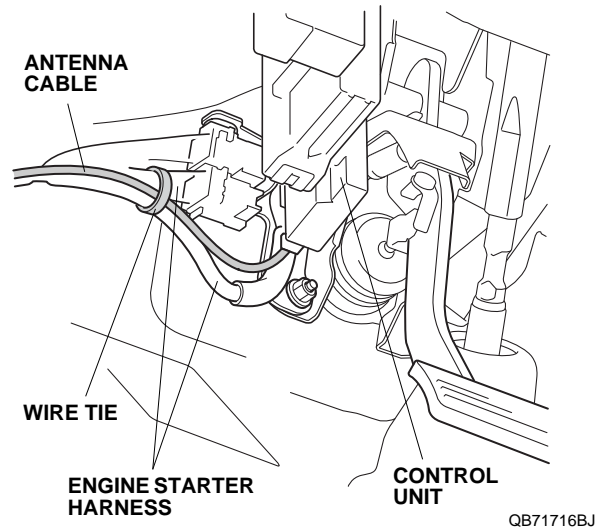

74. Bundle up the excess antenna cable as shown. Using one wire tie, secure the antenna cable and engine starter harness to the vehicle harness.

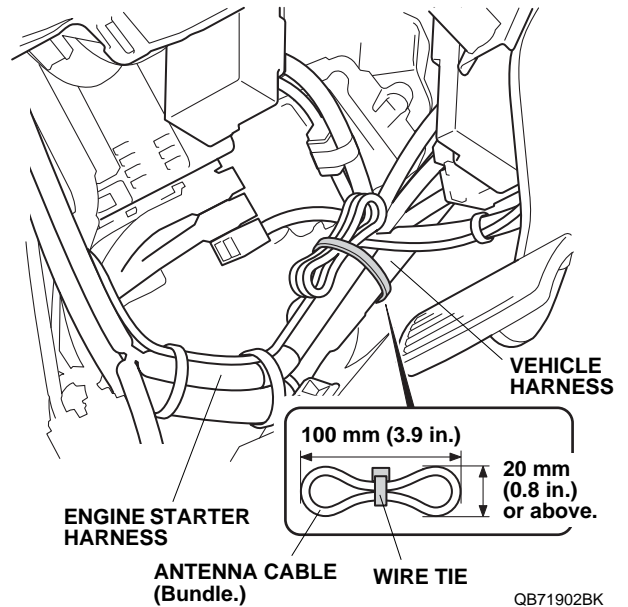

75. Using scissors, cut one urethane tape to the measurement shown. Using isopropyl alcohol on a shop towel, clean the vehicle unit (removed in step 25) where one urethane tape will attach.

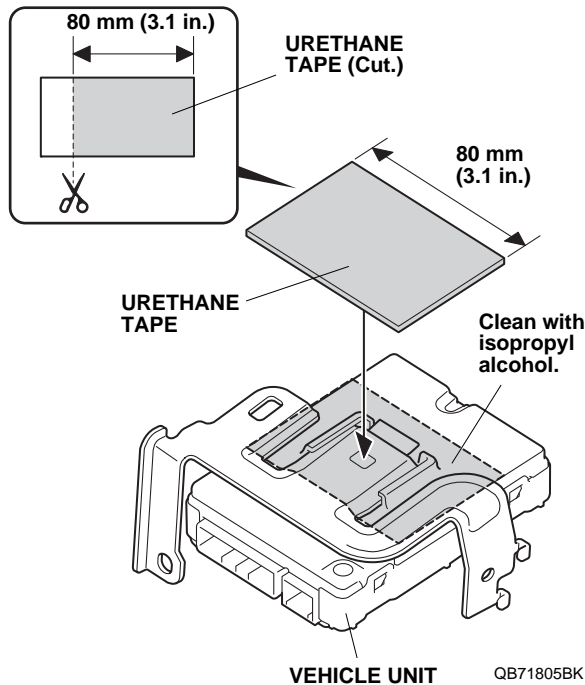

76. Attach the urethane tape to the vehicle unit in the area as shown. Reinstall the vehicle unit.
77. Using isopropyl alcohol on a shop towel, clean the lower column cover where one urethane tape will attach.

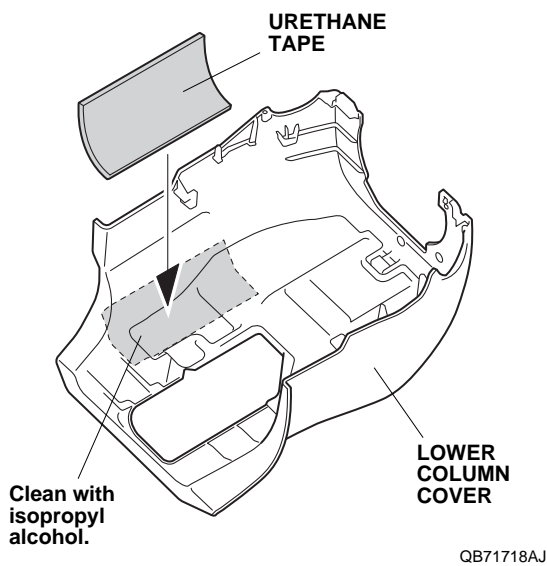

78. Attach the urethane tape to the lower column cover in the area as shown.

79. Using isopropyl alcohol on a shop towel, clean the hood where the caution label will attach.

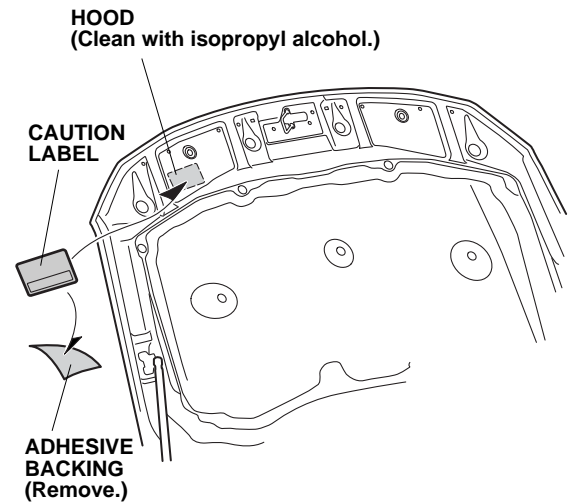

932517AS

80. Attach the caution label to the hood in the area shown.
81. Check that all wire harnesses are routed properly and all connectors are plugged in.
82. Check the overlap between the headliner and the driver's A-pillar trim. Refer to the service manual. If necessary, adjust the overlap.
83. Check the marks (step 66) of the nuts and the control unit bracket.
84. Reinstall all removed parts.
85. Reconnect the negative cable to the battery.
86. Enter the anti-theft codes for the radio and navigation systems, then enter the customer's radio presets.
87. Reset the clock.
88. Perform the "REMOTE ENGINE STARTER REGISTRATION" and the "FUNCTION CHECK".

REMOTE ENGINE STARTER REGISTRATION

1. Acquire the PCM Code from the Interactive Network.

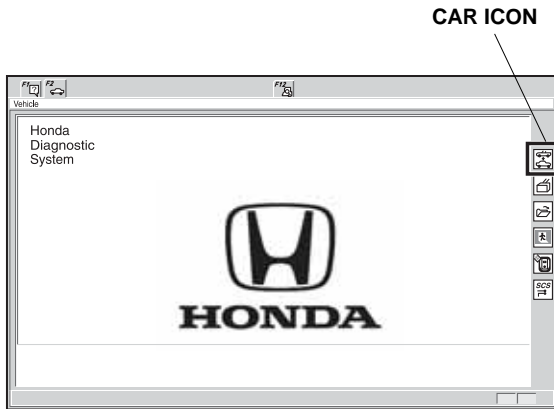

QB91102AJ

2. Connect the HDS/MVCI tester to the OBD II data link connector, then turn the ignition switch to the on (II) position.
3. Start the HDS, and click the car icon.
4. Input the VIN and other required information into the HDS, then click the check button.

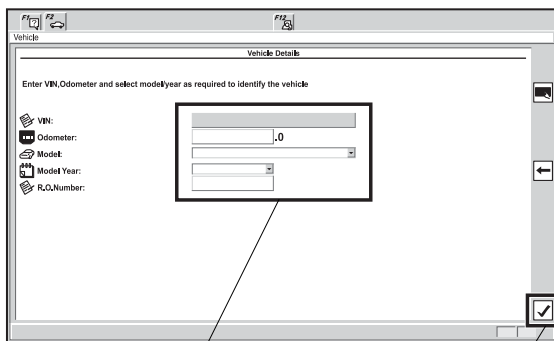

Input the VIN and other required information.

CHECK BUTTON

QB32102BH

5. Select **Honda Systems**, then click the check button.

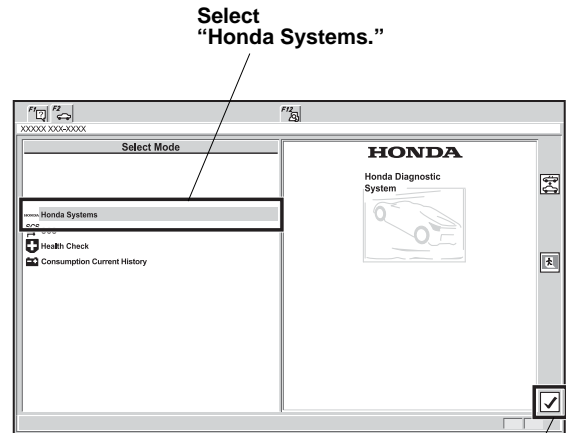

CHECK BUTTON

QB32103AH

6. Select **R/C ENG STARTER** and click the check button.

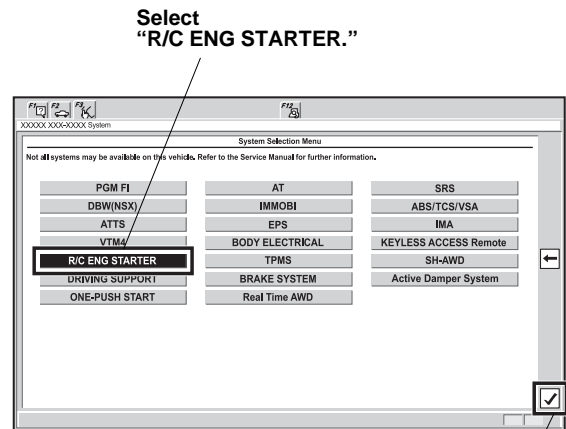

CHECK BUTTON

QB32104AH

7. Select **REGISTER REMOTE CONTROL ENGINE STARTER UNIT**, then click the check button.

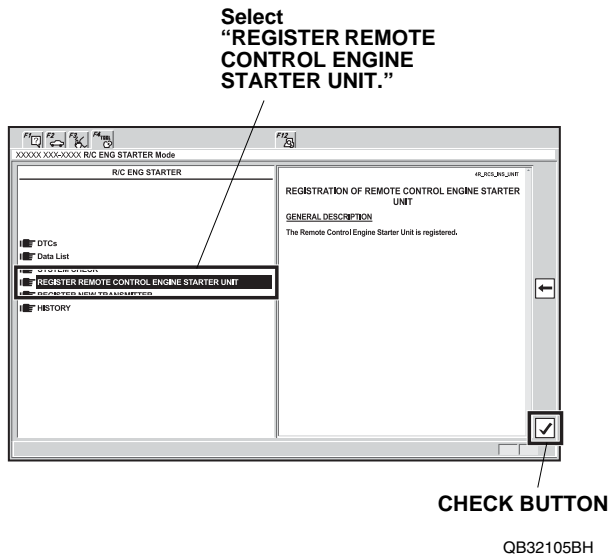

8. The following message will display: **Obtain PCM-code (IMMOBILIZER PCM CODE) from IN. This vehicle's VIN will be required to obtain the password. (USA)** Click the check button.

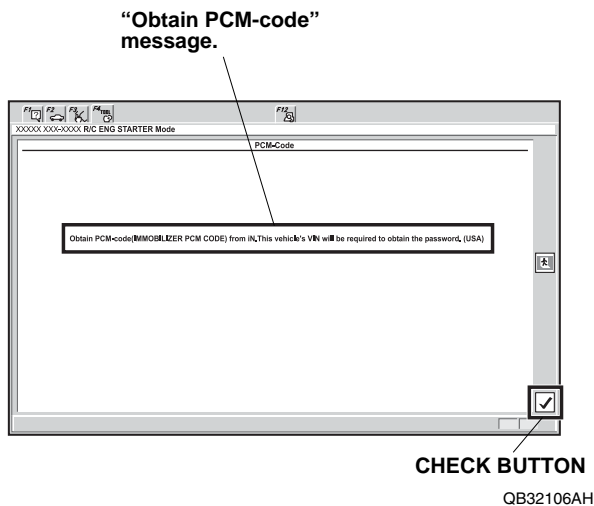

9. Input the PCM-code, then click the check button.
NOTE: To ensure security, the PCM-code (password) is changed everyday, so it is impossible to register the remote control engine starter if the dates of the PCM-code acquisition and registration are different. The date of the HDS/MVCI tester should also be the same.

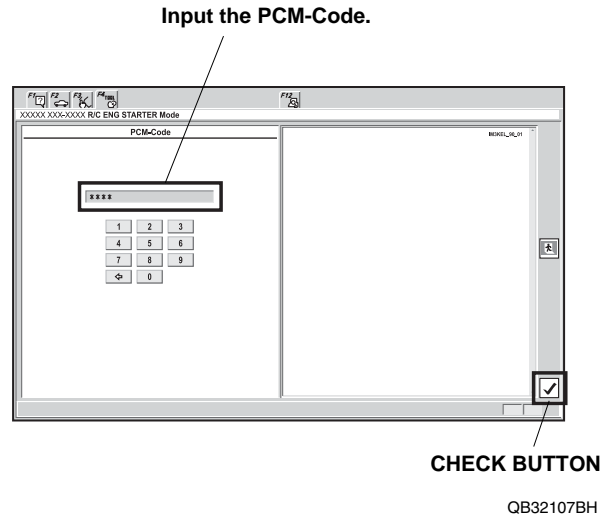

10. The following message will display: **The registration of the Remote Control Engine Starter Unit has been completed.** Turn the ignition switch off.

“The registration of the Remote Control Engine Starter Unit has been completed.”

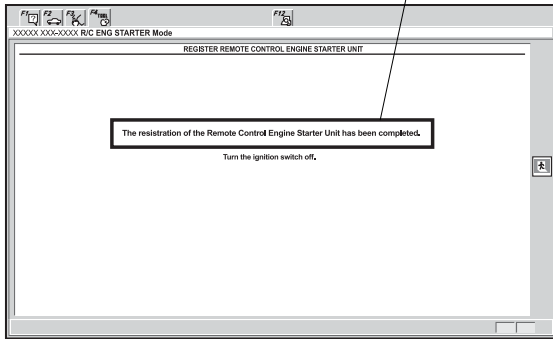

QB32108CH

11. The following message will display: **Check that engine can be started by the Transmitter.** Click the check button.

“Check that engine can be started by the Transmitter.”

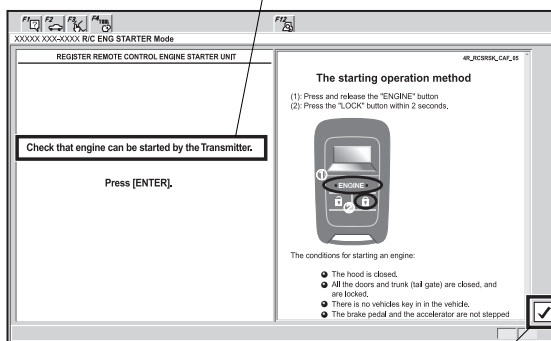

CHECK BUTTON QB32109CH

12. Perform the FUNCTION CHECK on page 25, then disconnect the HDS/MVCI.

FUNCTION CHECK

Operating Conditions

- The hood is closed
- The shift lever is in park
- Turn the ignition switch off and the key is outside the vehicle
- All doors and tailgate closed and locked

Inspection

1. Press the engine/command button on the transmitter and release, within 2 seconds, press the lock/start button on the transmitter.

The engine should start if all operating conditions are met. (Refer to the engine starter operation.)

Does the engine start?

Yes - Operation is normal.

No:

- Make sure all “Operating Conditions” are met.
- Check the engine starter harness connections.
- Connect the HDS/MVCI and check for an indicated failure. (Refer to the appropriate Service Manual for details.)

- Press the engine/command button on the transmitter and release, within 2 seconds, press the unlock/stop button. The engine should stop.

Does the engine stop?

Yes - Operation is normal.
No - Check the engine starter harness connections.

- After the engine has stopped, start the engine again, and check that the engine stops after each of the following conditions:

NOTE: After each test the ignition key must be cycled, or the driver's door must be opened and closed.

- Move the shift lever out of the P position.
- Unlock or open the doors or the tailgate.
- Open the hood.
- Insert the key in the ignition.
- Press the engine start/stop button.
- Press on the brake pedal.

Does the engine stop after each of these tests?

Yes - Operation is normal.
No - Check the engine starter harness connections.

- Check that the power windows and the moonroof do not function, and the shift lever does not move to any position when the engine is started with the transmitter.
- Check that the engine does not start under "Operating Conditions" with the key left inside the vehicle.
- Start the engine again, press the engine/command button on the transmitter two times, and check the vehicle condition on the display.
- Check the operation of the transmitter when the vehicle is 120 m (400 ft.) away and in direct sight.
- Press the unlock/stop button on the transmitter and verify that the doors unlock. Press the lock/start button, and verify that the doors lock.
- Check that the engine can start by the vehicle key and that the wiper and the headlight can be operated normally.

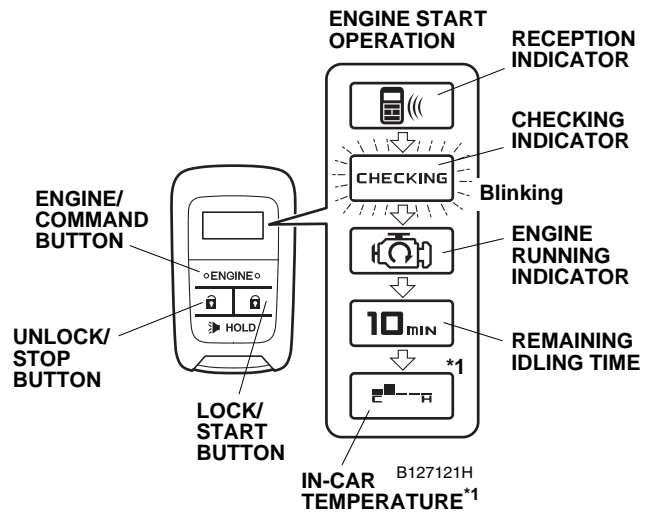

*1 Only on vehicles equipped with the automatic climate control. This indicator is displayed for some vehicles among them.